

**Section 7:**  
**Quicksheets**

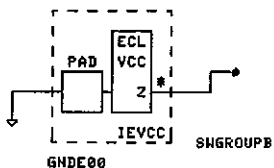

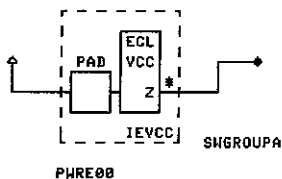
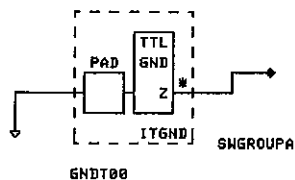
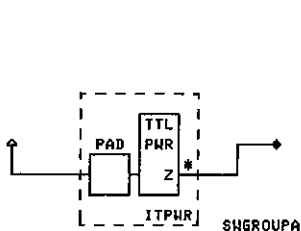
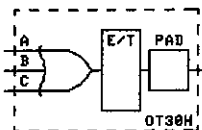
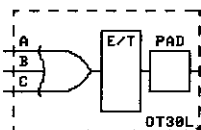
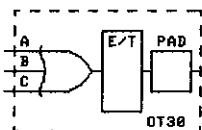
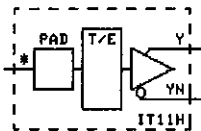
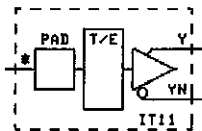

+5VREF ECL SYSTEM  
TAG TO APPROPRIATE SWITCH GROUP

STD REF ECL SYSTEM

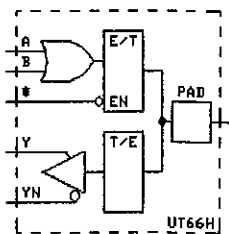
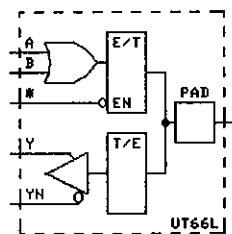
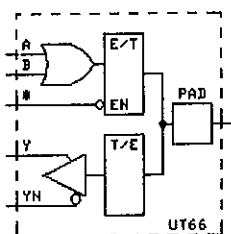
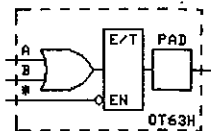
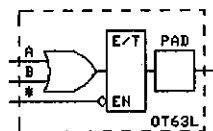
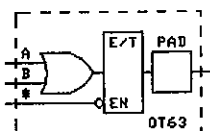
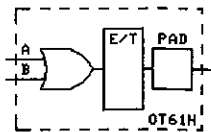
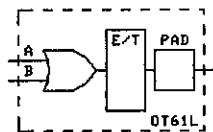
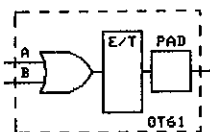
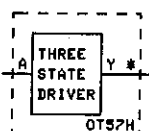
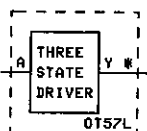
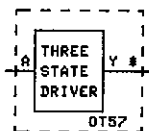
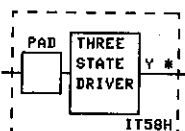
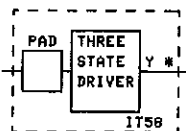
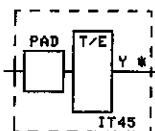
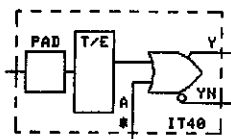

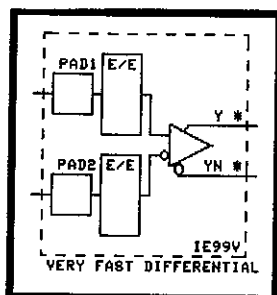
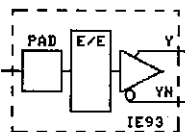
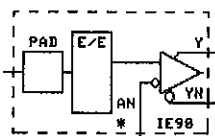
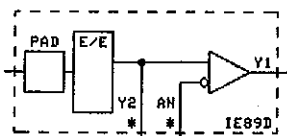
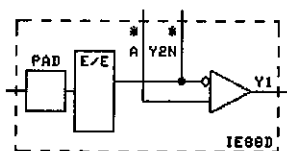
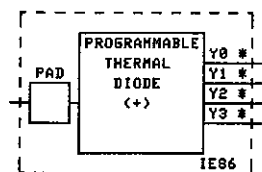
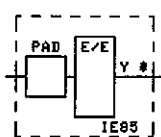
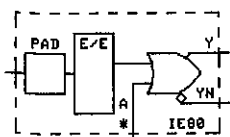
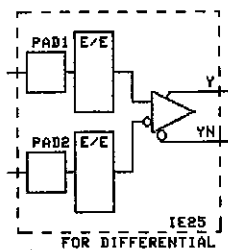
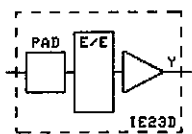

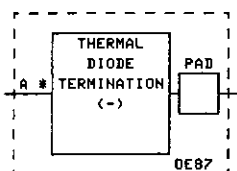
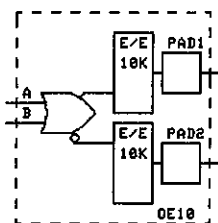
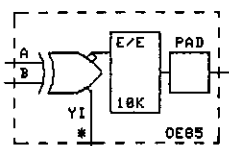
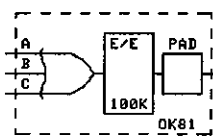
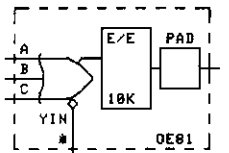
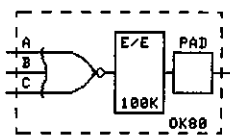
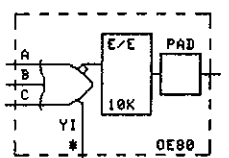
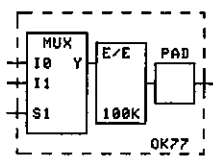
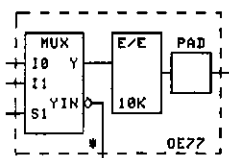
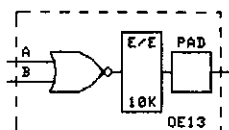

FOR HIGH-SPEED APPLICATIONS

USE WITH IE86 OR 6T99

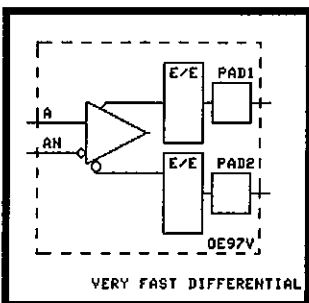
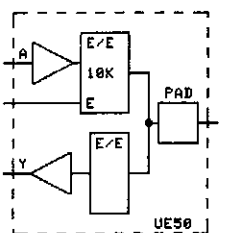

VERY FAST DIFFERENTIAL

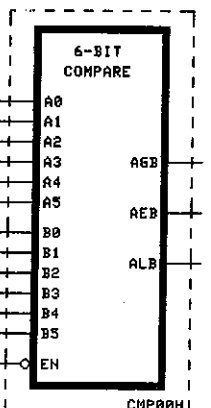
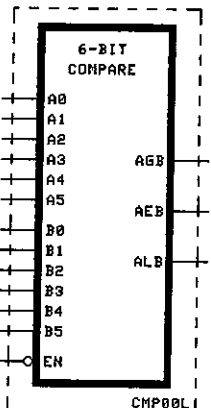
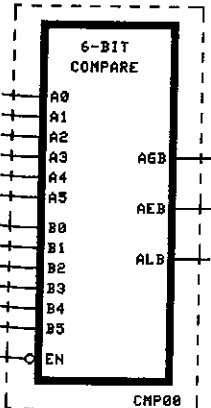
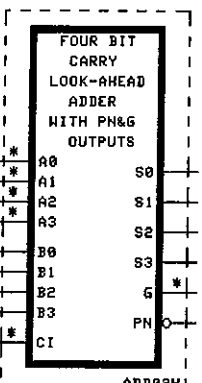
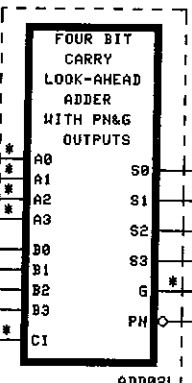
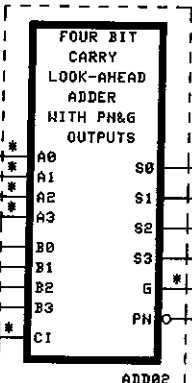
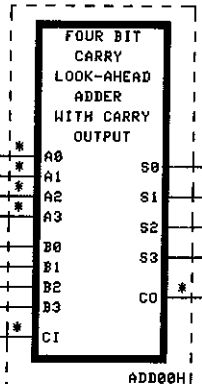
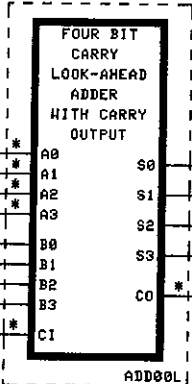
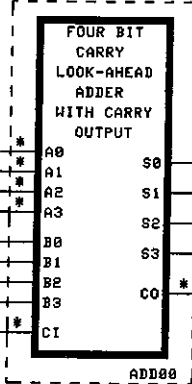
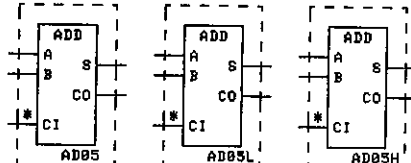

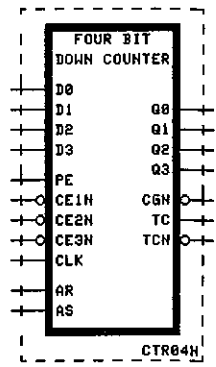
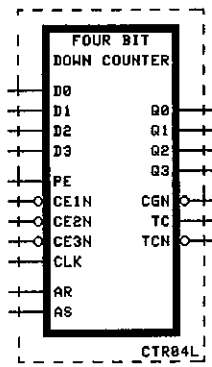
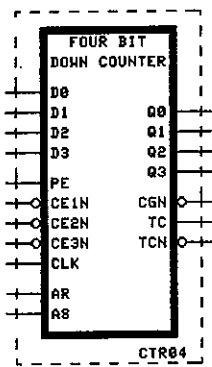
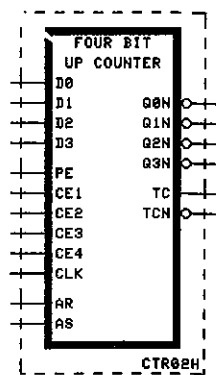
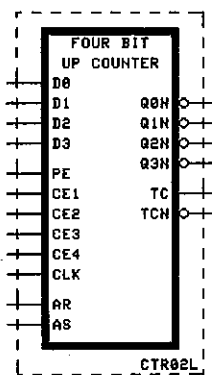
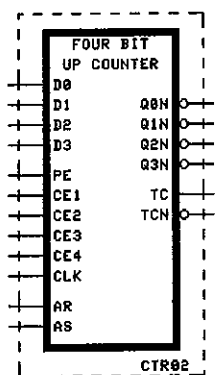
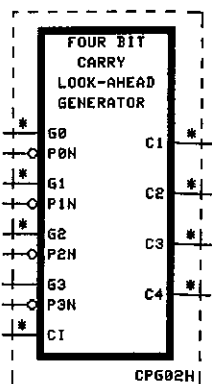
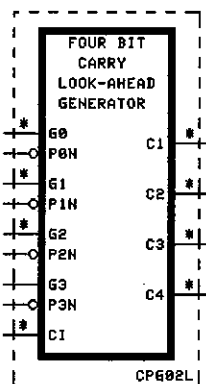
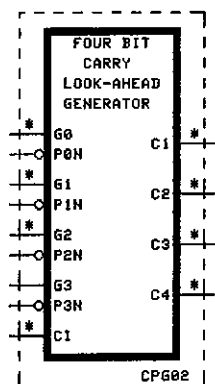



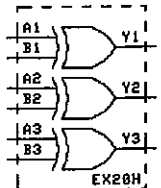
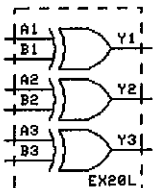
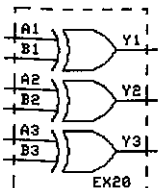
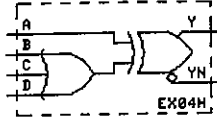
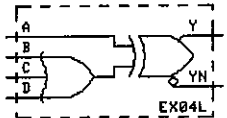
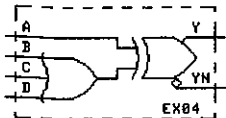
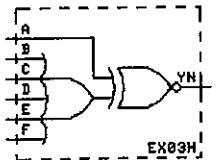
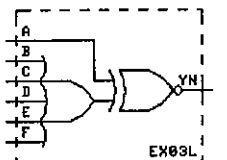
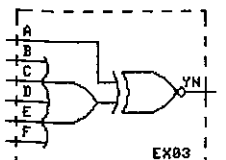
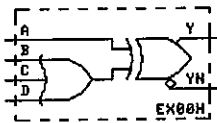
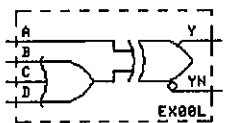
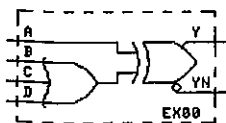
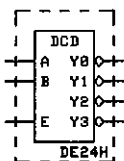
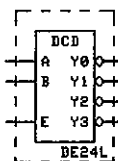
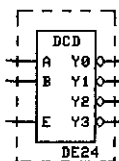
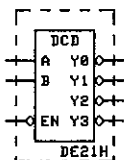
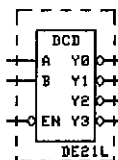
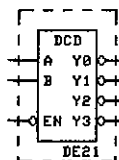
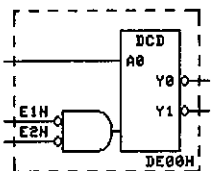
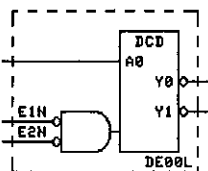
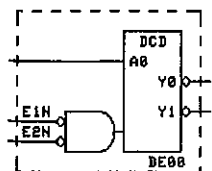

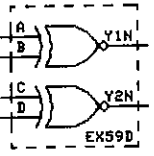
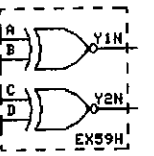
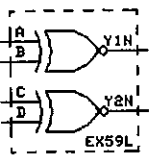
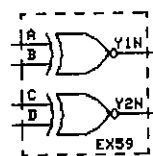
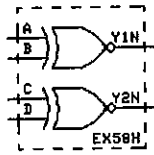
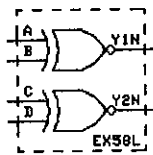
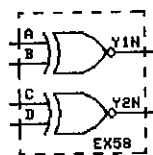
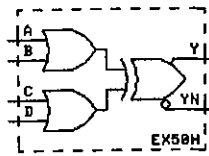
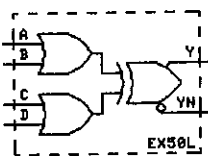
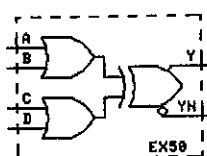
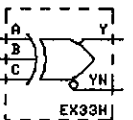
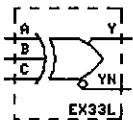
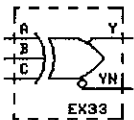
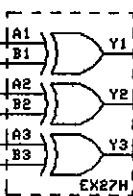
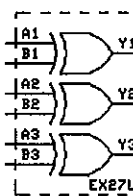
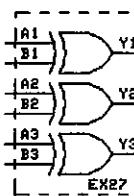
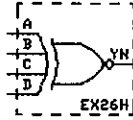
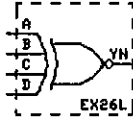
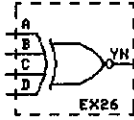
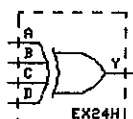
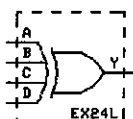
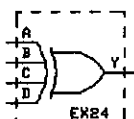

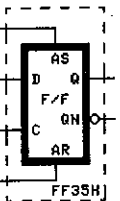
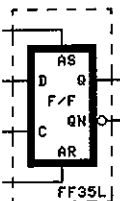
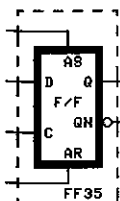
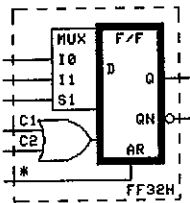
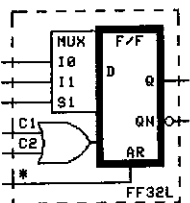
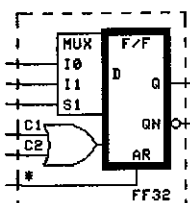
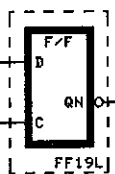
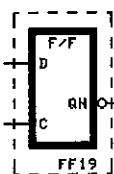
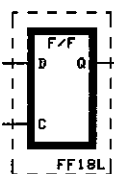
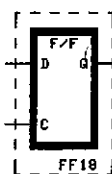
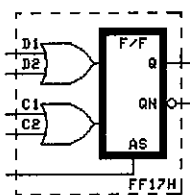
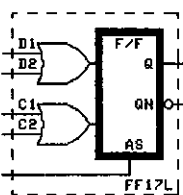
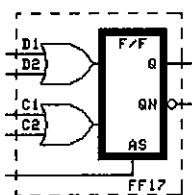
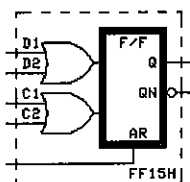
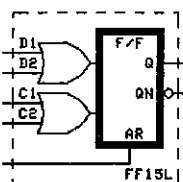
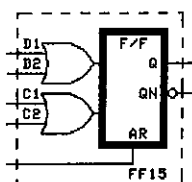
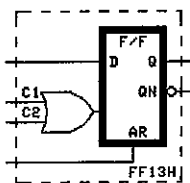
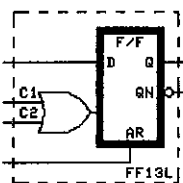
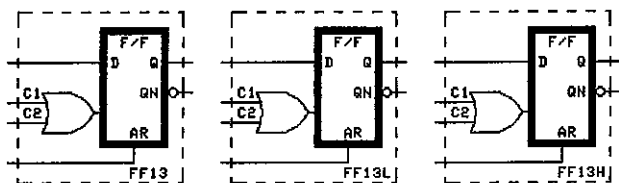

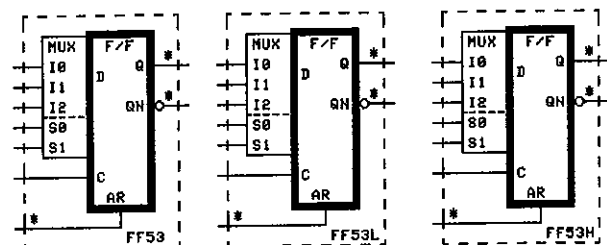
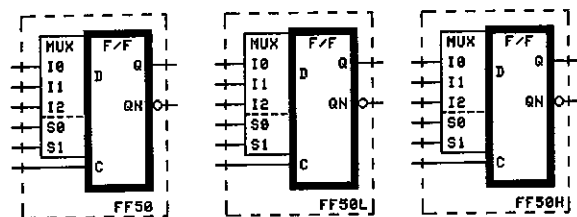
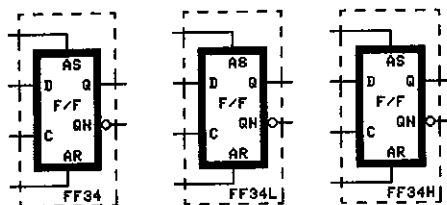

NO OPTIONS FOR THESE MACROS

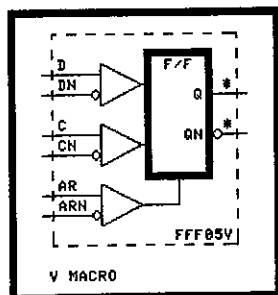
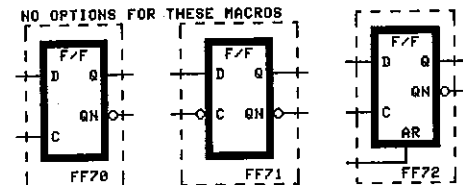

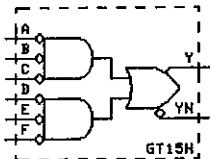
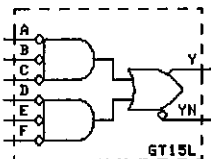
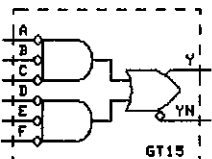
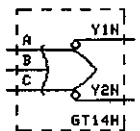
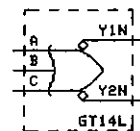
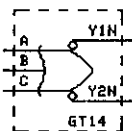
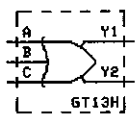
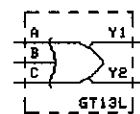
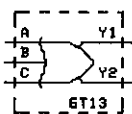
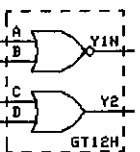
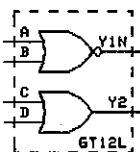
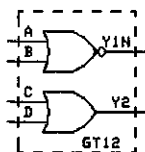
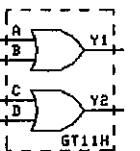
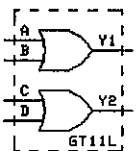
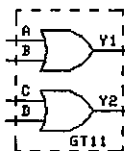
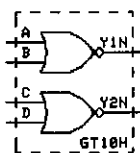
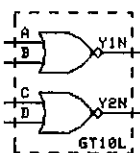
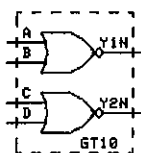
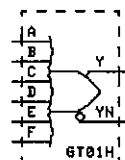
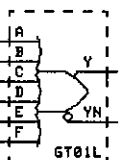
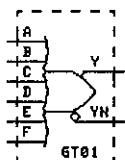
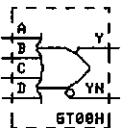
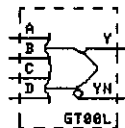
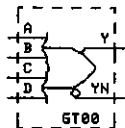

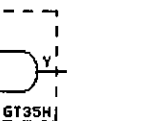
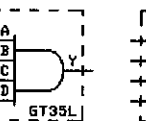
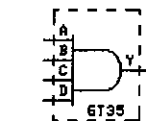
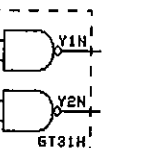
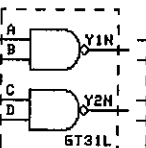
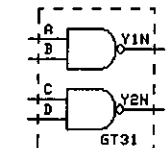
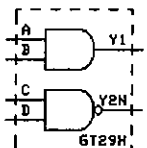
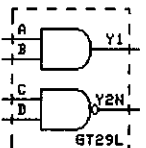
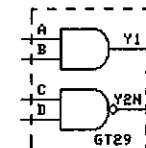
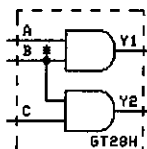
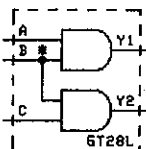
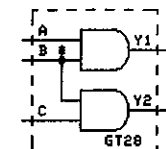
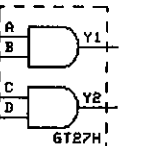
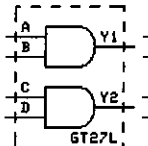
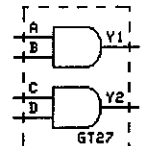
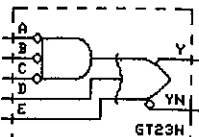
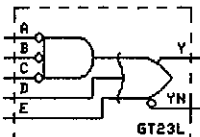
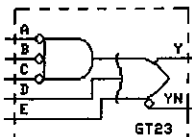
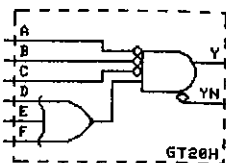
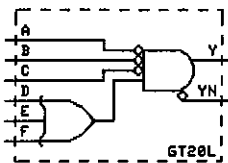
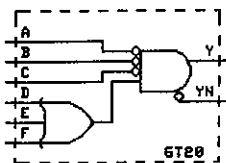

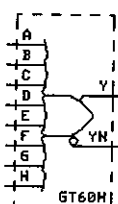
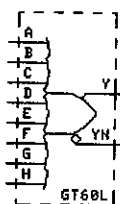
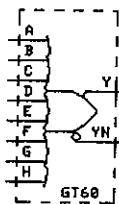
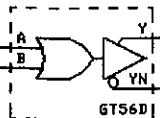
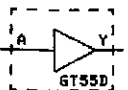
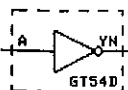
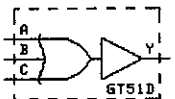
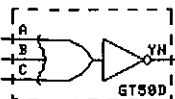
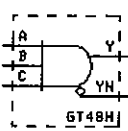
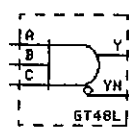
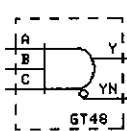
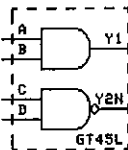
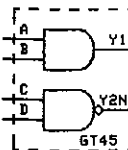
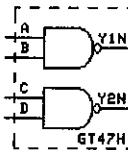
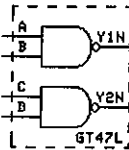
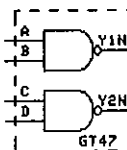
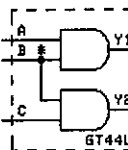
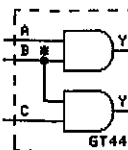
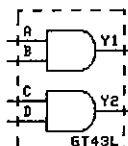
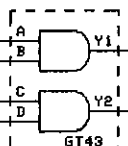
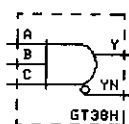
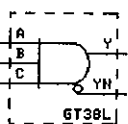
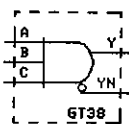
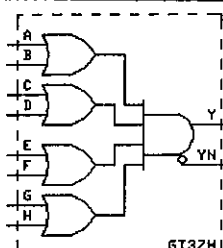
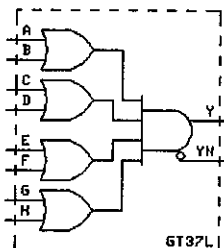
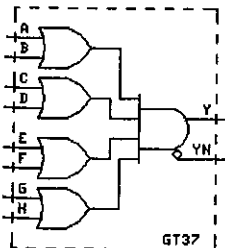

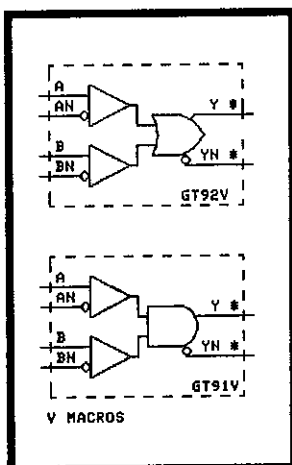
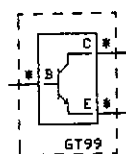
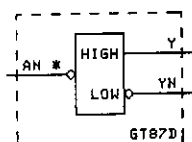
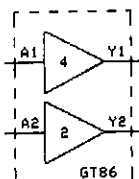
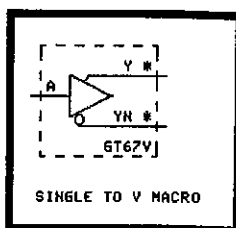
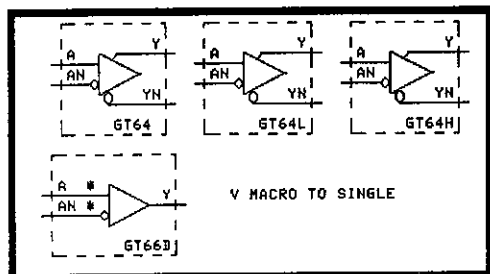
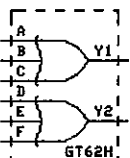
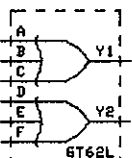
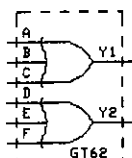
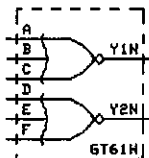
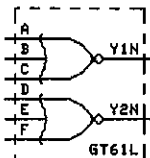
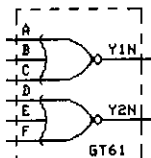

THERMAL DIODE



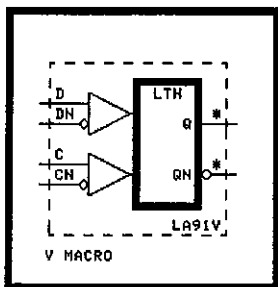
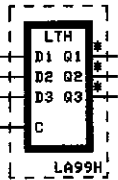
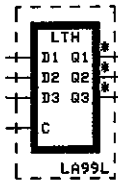
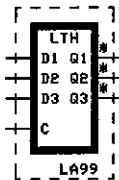
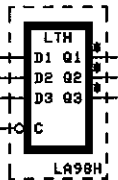
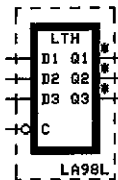
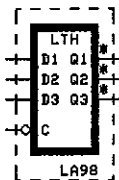
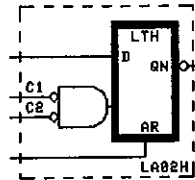
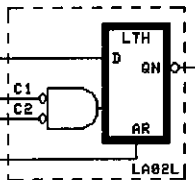
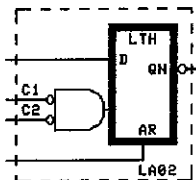
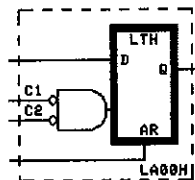
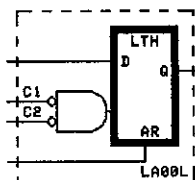
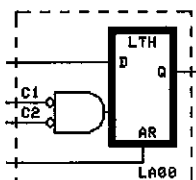

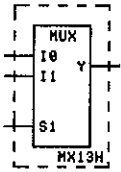
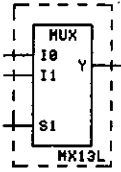
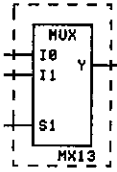
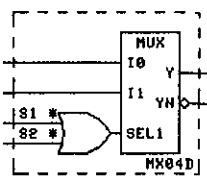
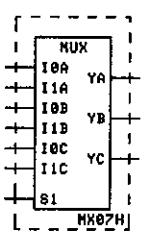
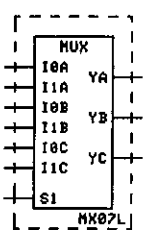
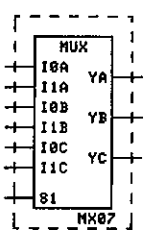
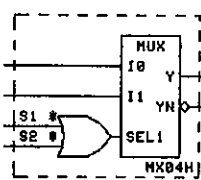
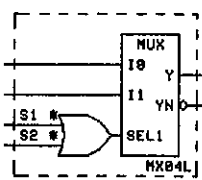
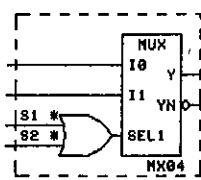
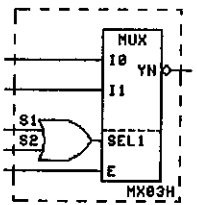
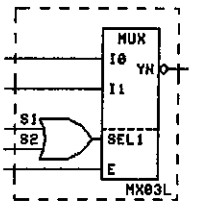
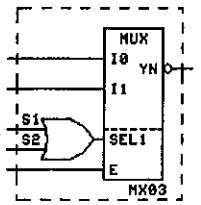
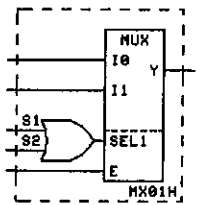
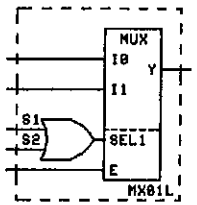
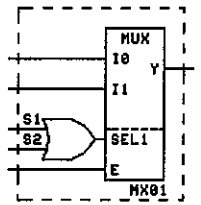
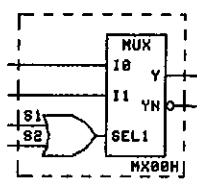
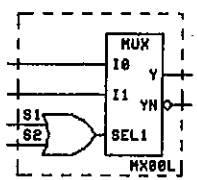
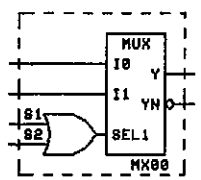

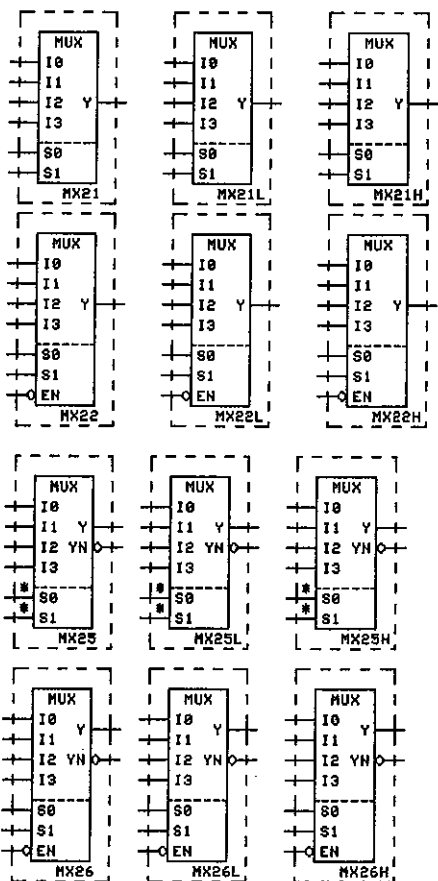
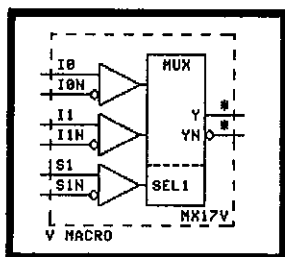

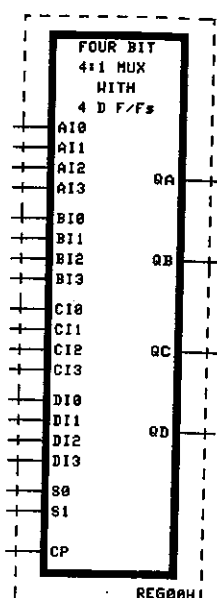
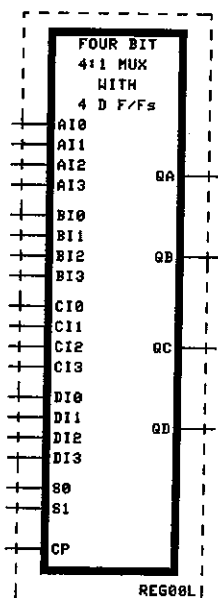
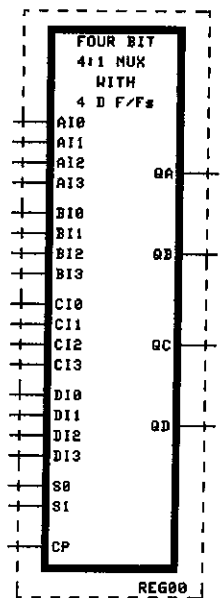

WIRE0R2



WIRE0R3



WIRE0R4

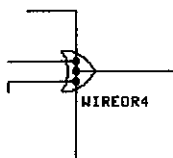

WIRE0R4

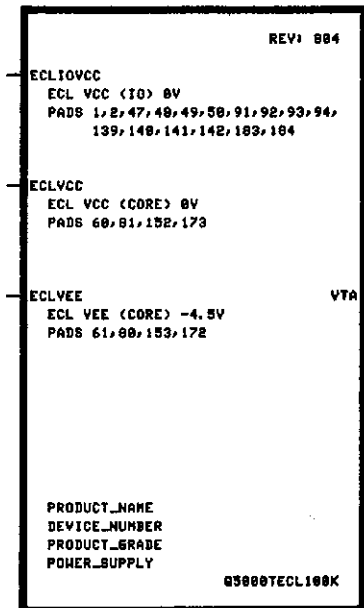
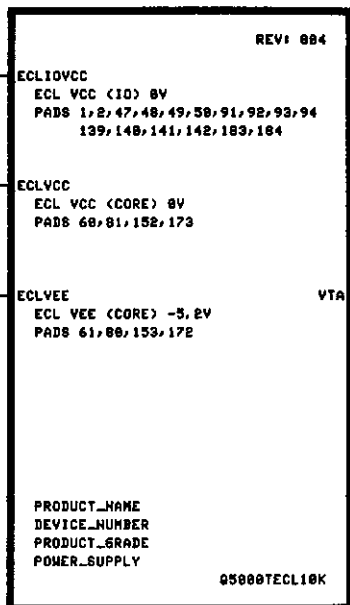
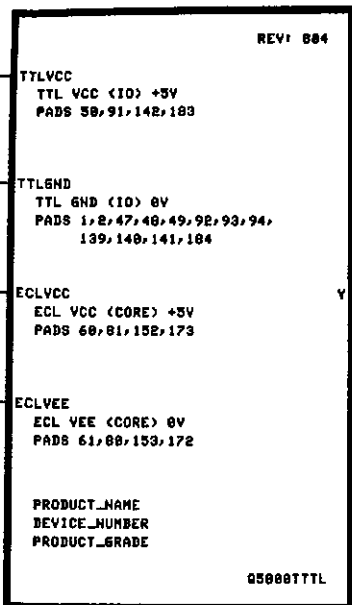

POWER SUPPLY CAN BE STD4, STD5 OR SVREF

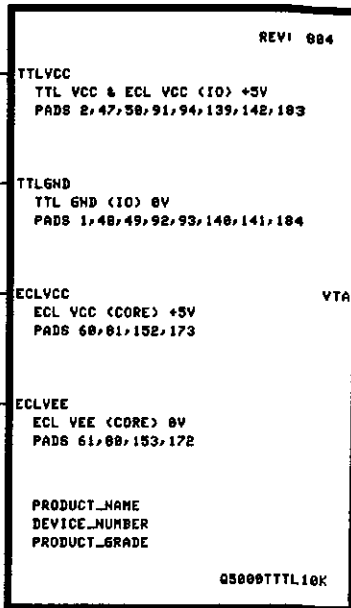
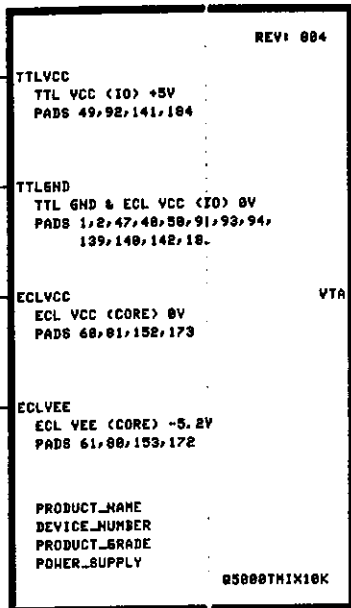

CAN HAVE POWER SUPPLY PARAMETER WITH STD4 OR STD5 AS VALUE

